

Data and specifications are only available as information
Brandoni S.p.A. reserves the right to modify one or more valve specifications without warning.

DT078
P.C.04/12-2005/GB

Construction details

Ball valves

Series 04

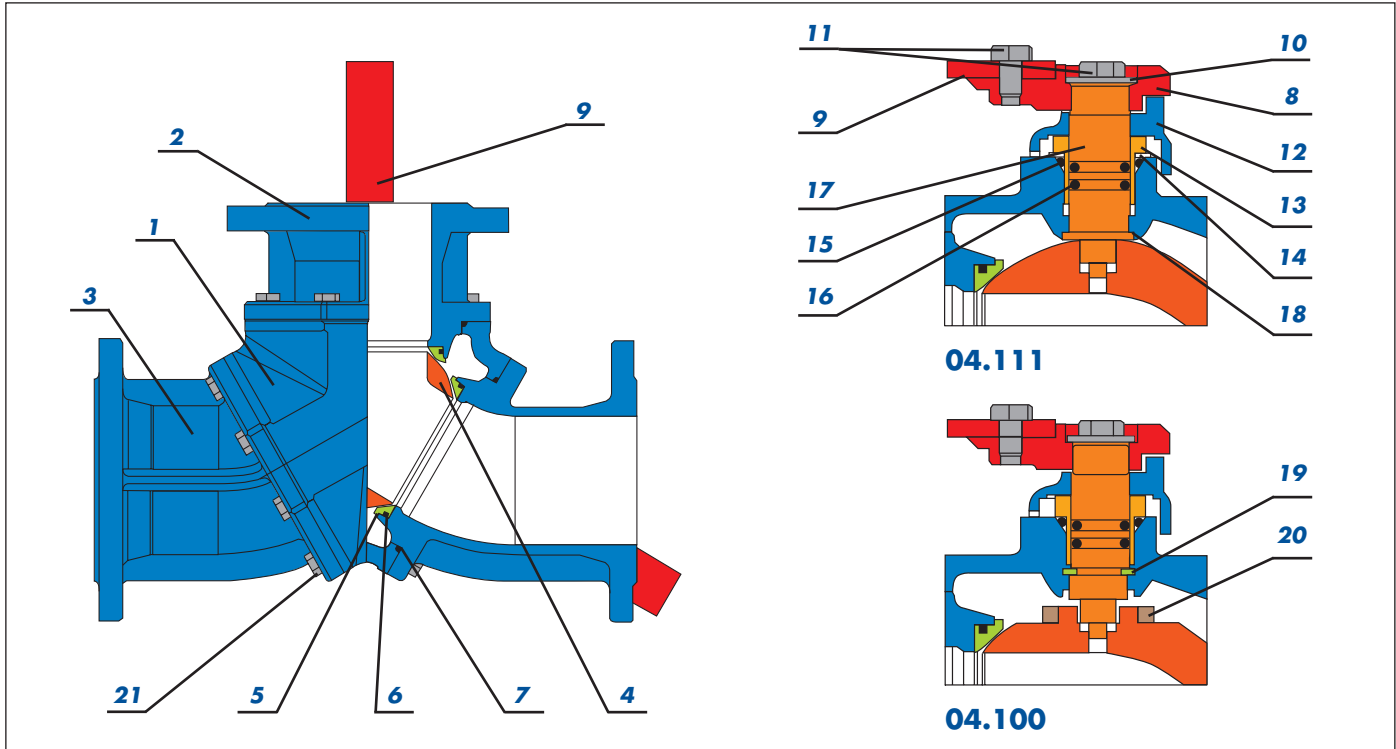

4.100

4.111

N°	Description	Quant.	4.100	4.111
1	Body	1	GGG40 Cast iron	
2	Flange	1	GG25 Cast iron	
3	Bent flange	2	GG25 Cast iron	
4	Ball	1	Brass G/CuZn40Pb2	AISI 304
5	Ball seat	3	PTFE + Graphite	
6	O-ring	3	NBR/Viton®	
7	O-ring	3	NBR/Viton®	
8	Lever hub	1	Fe 360 Zn	
9	Lever	2	Fe 360 Zn	
10	Washer	1	C30 ZN	
11	Screw	3	C30 ZN	
12	Ro-stop	1	Brass G/CuZn40Pb2	
13	Bushing	1	Brass P/CuZn40Pb2	AISI 304
14	Ring	1	-	Brass P/CuZn40Pb2
15	O-ring	1	NBR/Viton®	
16	O-ring	2	NBR/Viton®	
17	Stem	1	Brass P/CuZn40Pb2	AISI 304
18	Ring	1	-	PTFE
19	Ring	1	Brass P/CuZn40Pb2	-
20	Ring	1	Brass P/CuZn40Pb2	-
21	Screw	12-24	C40 Zn	

Via Novara, 199 - 28078 Romagnano Sesia (No) ITALY
Tel. +39 0163 8281 11 - Fax +39 0163 8281 30
Internet: www.brandoni.it

